

Automatic cut-off of electrical equipment's when no human presence is detected

Introduction:

- This project aims to automate electrical appliances like lights, fans, etc. in a room according to the presence of humans.
- Most of the times we see there is a lot of power is being wasted such as when someone is leaving a room, the person may forget to turn off lights or fans in that room, or in public toilets all appliances like lights, exhaust fans, etc keep running throughout the day even we are using them or not.
- This kind of wastage is mainly seen in public places such that class rooms, hostels, corridors, public toilets, etc.
- This problem can be solved by having a mechanism, which can detect presence of humans in that area and accordingly turns on or off the electrical appliances.

Motivation:

- We have observed that most people in our institute leaves the classrooms just after the professor had left and no one bothers about turning off lights and fans in that room. They remain turned on until someone notices them and turns them off.
- We have also observed that most of the students in our hostels leave their rooms without switching off lights and fans in their rooms.
- We have also seen that the lights and exhaust fans in toilets of our institutes are never switched off.
- We have estimated that for a typical hostel building consisting of 150 rooms and 20 toilets, consider that each room has 3 tube-lights and 2 fans, each toilet has 4 tube-lights and 2 exhaust fans, even a minimal wastage is happened we can save 215Kwh of energy per day.

- If 1 Kwh costs around 6 rupees, then this could save us around 1200 rupees in a single hostel in a single day.
- If the power wastage is minimized in every hostel, class-rooms, toilets, etc this could save about lakhs of rupees in a month in our single institute.
- If this is successfully implemented in our college it may inspire many other institutes so that we can save a lot of energy in our country.
- While there are so many villages which do not get proper electricity, this could help them cater their needs.

Project details :

The above problem can be solved by having a mechanism which turns off the electrical equipment's like lights and fans in a room when there is no human is present in the room.

This can be done by installing a unit containing the following parts:

1. PIR Motion detection sensor.
2. Relay.
3. Power supply unit.

1.PIR Motion detection sensor :

PIR sensors allow you to sense motion, almost always used to detect whether a human has moved in or out of the sensors range. They are small, inexpensive, low-power, easy to use and don't wear out. They are often referred to as PIR, "Passive Infrared", "Pyroelectric", or "IR motion" sensors.

PIRs are basically made of a pyroelectric sensor (which you can see above as the round metal can with a rectangular crystal in the center), which can detect levels of infrared radiation. Everything emits some low level radiation, and the hotter something is, the more radiation is emitted. The sensor in a motion detector is actually split in two halves. The reason for that is that we are looking to detect motion (change) not average IR levels. The two halves are wired up so that they cancel each other out. If one half sees more or less IR radiation than the other, the output will swing high or low.

This sensor is mounted on a circuit board and with a circuitry it forms a module. Now this module simply give output **HIGH** in the presence of IR radiation i.e, Human beings, and give an output **LOW** when absence is confirmed. This output signal can be used to operate a relay which further switches the desired electrical appliances.

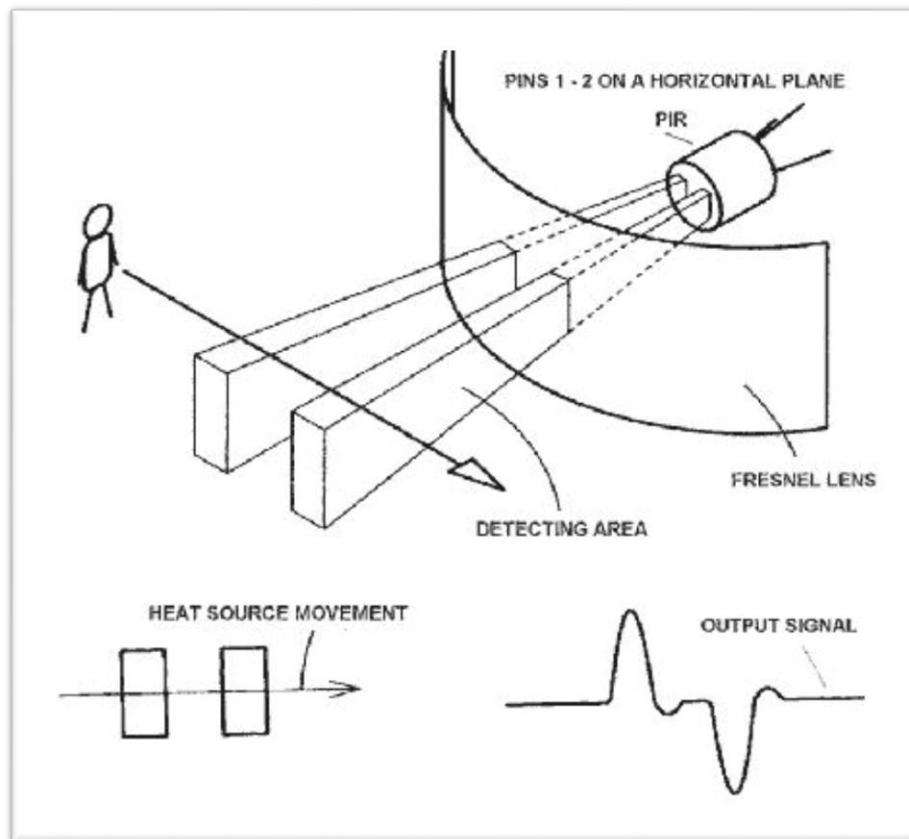

The IR sensor itself is housed in a hermetically sealed metal can to improve noise/temperature/humidity immunity. There is a window made of IR-transmissive material (typically coated silicon since that is very easy to come by) that protects the sensing element. Behind the window are the two balanced sensors.

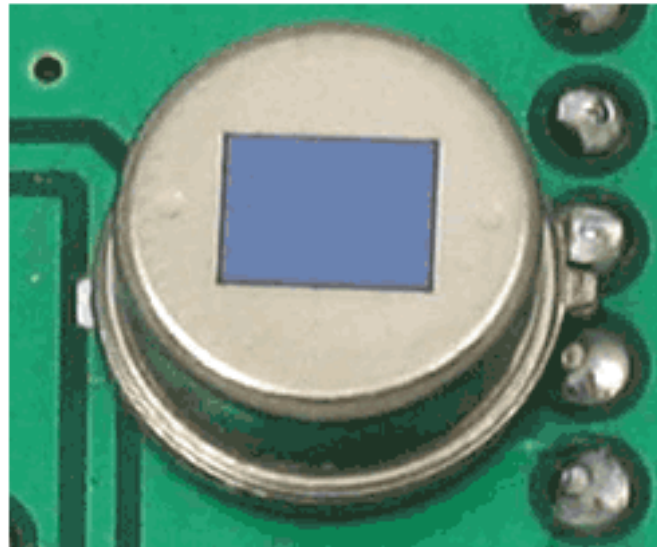
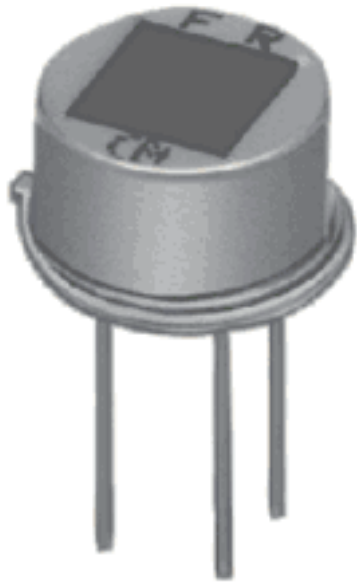

PIR motion detection sensor

This PIR sensor is mounted on a circuit board with some circuitry to form a module and it is cheaply available in the market.

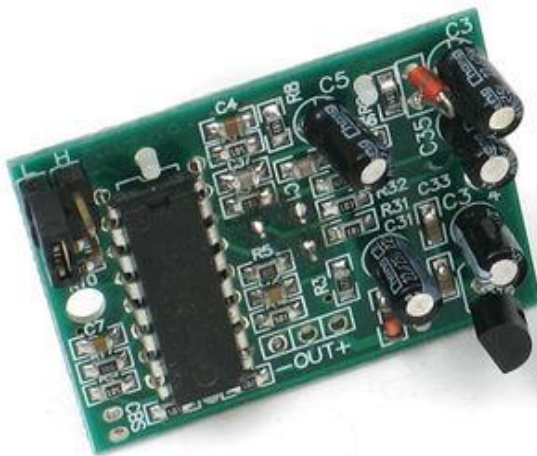

PIR motion detection sensor module

2.Relay

- Since we are getting a 5V output from a PIR sensor and with this signal we are interested to operate Ac mains, so we need a component which deals with ac mains supply by receiving command from a 5V device.
- Relays are switches that open and close circuits electromechanically or electronically.
- Relays control one electrical circuit by opening and closing contacts in another circuit.
- As relay diagrams show, when a relay contact is normally open (NO), there is an open contact when the relay is not energized. When a relay contact is Normally Closed (NC), there is a closed contact when the relay is not energized. In either case, applying electrical current to the contacts will change their state.

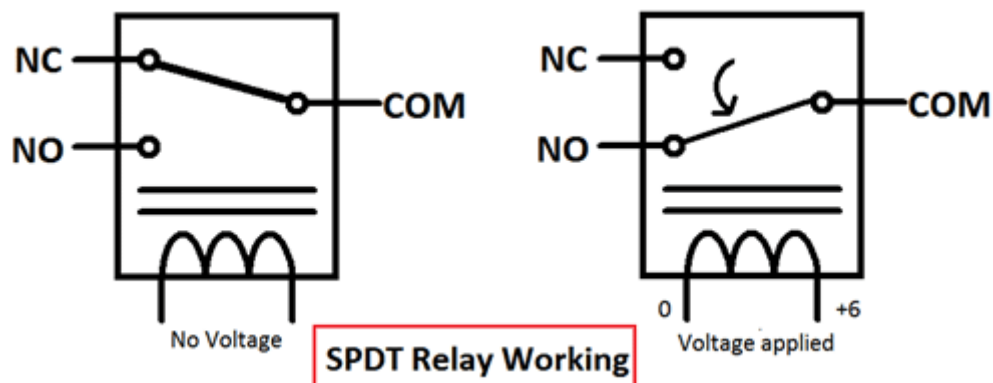

Basically there are two types of relays:

1. Electromechanical relays.
 2. Solid State relays.
- The decision to use electromechanical or solid state relays depends on an application's electrical requirements, cost constraints and life expectancy.
 - Although solid-state relays have become very popular, electromechanical relays remain common.
 - Many of the functions performed by heavy-duty equipment need the switching capabilities of electromechanical relays.
 - Solid State Relays switches the current using non-moving electronic devices such as silicon controlled rectifiers.

Electromechanical Relays:

Basic parts and functions of electromechanical relays include:

1. **Frame:** Heavy-duty frame that contains and supports the parts of the relay.
2. **Coil:** Wire is wound around a metal core. The coil of wire causes an electromagnetic field.
3. **Armature:** A relays moving part. The armature opens and closes the contacts. An attached spring returns the armature to its original position.
4. **Contacts:** The conducting part of the switch that makes (closes) or breaks (opens) a circuit.

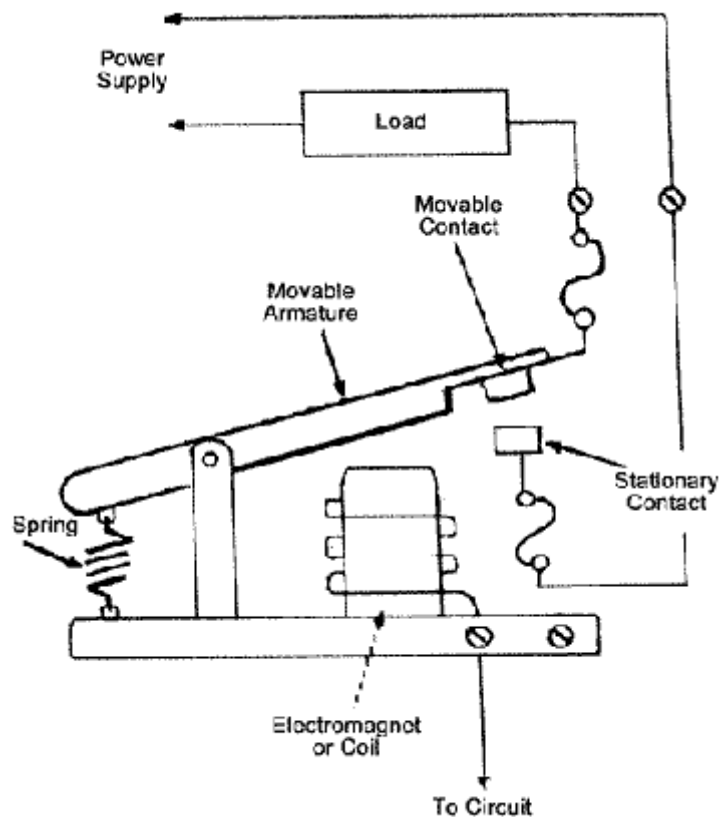

Relays involve two circuits: the energizing circuit and the contact circuit. The coil is on the energizing side; and the relays contacts are on the contact side. When a relays coil is energized, current flow through the coil creates a magnetic field. Whether in a DC unit where the polarity is fixed, or in an AC unit where the polarity changes 120 times per second, the basic function remains the same: the magnetic coil attracts a ferrous plate, which is part of the armature. One end of the armature is attached to the metal frame, which is formed so that the armature can pivot, while

the other end opens and closes the contacts. Contacts come in a number of different configurations, depending on the number of Breaks, poles and Throws that make up the relay. For instance, relays might be described as Single-Pole, Single-Throw (SPST), or Double-Pole, Single-Throw (DPST). These terms will give an instant indication of the design and function of different types of relays.

- **Break** -This is the number of separate places or contacts that a switch uses to open or close a single electrical circuit. All contacts are either single break or double break. A single break (SB) contact breaks an electrical circuit in one place, while a double break (DB) contact breaks it in two places. Single break contacts are normally used when switching lower power devices such as indicating lights. Double break contacts are used when switching high-power devices such as solenoids.
- **Pole** -This is the number of completely isolated circuits that relays can pass through a switch. A single-pole contact (SP) can carry current through only one circuit at a time. A double-pole contact (DP) can carry current through two isolated circuits simultaneously. The maximum number of poles is 12, depending upon a relays design.
- **Throw** -This is the number of closed contact positions per pole that are available on a switch. A switch with a single throw contact can control only one circuit, while a double-throw contact can control two.

3. Power supply design:

- The ac mains supply is available on the spot and it will be the best source to power the unit.
- Since our unit operates at 5v and we are dealing with ac mains, we need to convert this 220-240V AC to 5V DC.
- For that task we have to design a power supply.
- A good power supply will have following parts:
 1. Transformer (stepping down).
 2. Rectifier (AC to DC conversion).
 3. Filters

A simple power supply looks like the figure shown below:

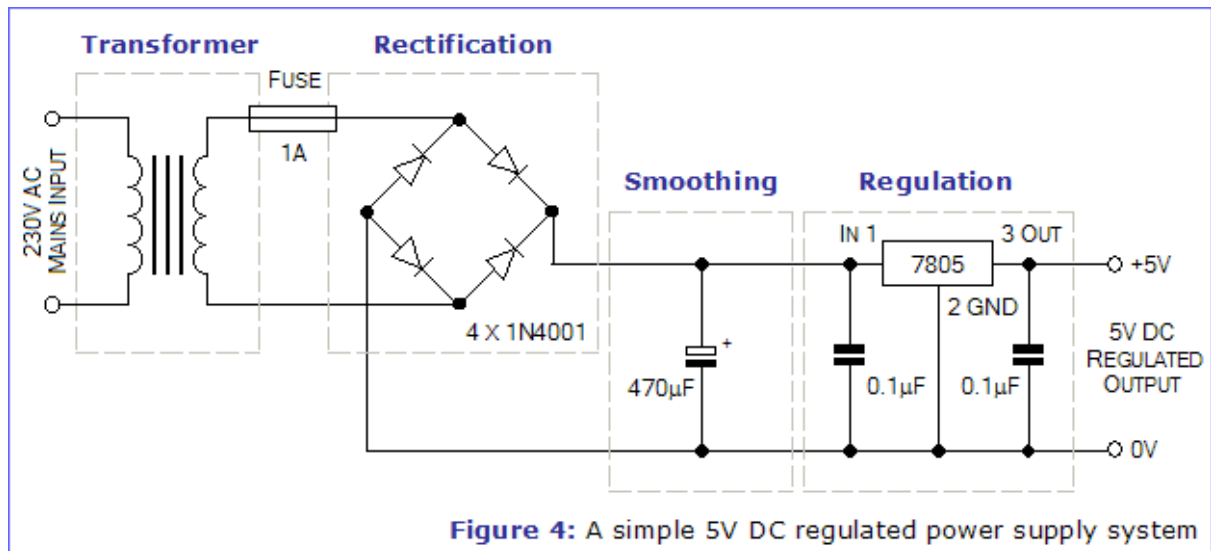

Conclusion :

- The entire circuit can be fabricated on a single PCB and can be easily installed just after MCB of any room.
- The installation of each unit takes around 500 rupees.
- Though it takes some investment in the beginning it can save energy of its worth in 2-3 months.
- Since, there are no parts which wears out there will be very less or zero maintenance and it can function for several years.

Proposal by:

1. *Satyasree Kantamani (14/EE/ , Final year Student, Electrical Engineering Department)*
2. *Lokesh Nandanwar (15/IT/45, Third year Student, Computer Science and Engineering Department)*
3. *Swati Kanchan (15/IT/95 ,Third year Student, Computer Science and Engineering Department)*
4. *Saivaraprasad Bolloju (16EC80054, Second year Student, Electronics and communication Engineering Department)*